

MOTOR GUARD CORPORATION

MODEL M-830 SHOP AIR DIAPHRAGM REGULATOR

INSTALLATION

The M-800 Shop Air Management System combines a high efficiency particulate and water removal filter, an effective oil removal filter and a high-flow, balanced valve regulator into a first line of defense for your compressed air system.

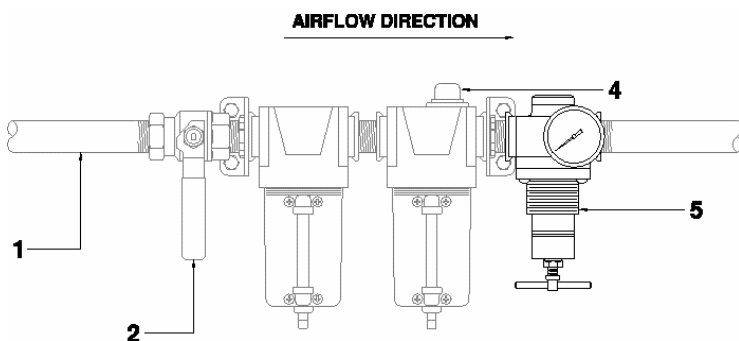

FEATURES

- Highly visible gauge
- True relieving type diaphragm regulator
- Reduces pressure creep
- Full adjustment over pressure range

SPECIFICATIONS

Maximum Airflow:	250 CFM
Operating Temperature Range:	40-120 F
Maximum Inlet Pressure:	250 PSI
Outlet Pressure Range:	2-125 PSI

Unit is designed for installation in a 3/4" line, use appropriate fittings for installation in other line sizes. Apply pipe thread compound to male thread connections. Before installing unit, relieve upstream pressure completely. Install unit level and in direction of airflow as noted. Unit should be mounted to a rigid structure and should not be supported by the supply line.

WARNING: This product is intended for use in industrial compressed air systems only. Do not install where pressures or temperatures can exceed those listed above.

Pressurize slowly to avoid high-pressure surge.

OPERATION

Open service valve (2) fully so that handle is parallel to inlet pipe. Turn T-handle on regulator (5) clockwise to increase air pressure, counter-clockwise to decrease. To reduce pressure setting, first reduce pressure to a setting lower than desired, then increase to the desired setting.

Inspect daily for leaks.

Regulator should be disassembled, cleaned and serviced periodically.

580 CARNEGIE STREET
MANTECA, CA 95337

1-800-227-2822
FAX 209-239-5114

www.motorguard.com

Rev 11/07 33149

MAINTENANCE

WARNING: Shut off air supply and drain residual pressure before attempting to service any part of the system!

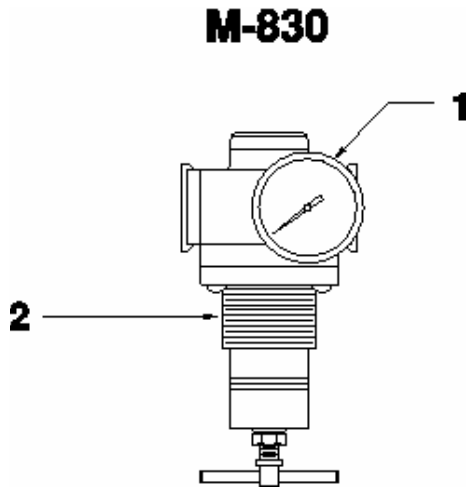

Replacement Parts

Key	Part No	Description
1	RG4045	Gauge, 2", 160 psi
2	MP0026	Regulator Diaphragm Kit

LIMITED WARRANTY

Motor Guard Corporation assumes the responsibility of providing equipment that is free from defects in workmanship and material. Should this product fail due to a defect in workmanship or material, Motor Guard Corporation will repair or, at its option, replace the product without charge, other than the transportation charges, provided that the product is returned to the factory, transportation prepaid, within one year of the date of purchase. Please contact Motor Guard Corporation for return authorization and shipping instructions.

This limited warranty does not cover damage to the product due to neglect, misuse or accident, nor does it cover any loss, damage or expense, either direct, indirect or consequential, arising from the non-function of this product. This limited warranty notice replaces any other warranty information, implied or otherwise, enclosed with this product or appearing in literature referring to this product.

Build a Complete Shop Air System with These Air Management Products from Motor Guard

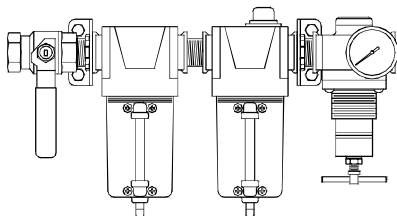

***Shop Air Management System
M-800***

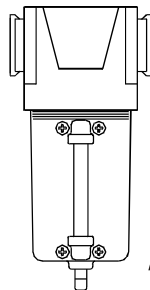

***Particulate Filter
M-810***

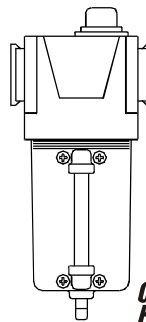

***Oil Removing Filter
M-820***

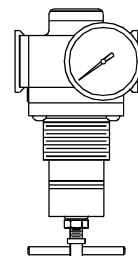

***Precision Air Regulator
M-830***