

MOTOR GUARD CORPORATION

MODEL MHT-7100 HIGH TECH COMPRESSED AIR FILTER

INSTALLATION

The MHT-7100 High Tech Air Compressed Air Filter is a high-efficiency, high-capacity water trap / compressed air filter with an advanced hydrophilic media cartridge. The filter removes particulates, condensed moisture and oil aerosols from compressed air for spray booths and critical refinishing operations and provides for the quickest, cleanest cartridge change in the industry.

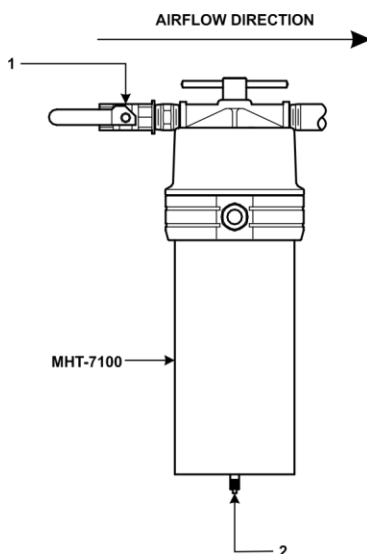

FEATURES

High-volume water trap combined with a hydrophilic depth cartridge that removes particulates, oil and water aerosols. Overnight drain valve drains accumulated moisture when pressure is off. Uses (1) **M-710** drop-in replacement cartridge.

SPECIFICATIONS

Inlet/Outlet Size:	1/2 NPT
Nominal Airflow Rating:	30 SCFM
Filtration Rating:	.01 Micron
Maximum Inlet Pressure:	125 PSIG
Operating Temperature Range:	40-120 °F

Install unit in spray booth or near critical operation with at least 20 feet of supply line between unit and compressor. Failure to maintain this distance will cause excessive water vapor to pass through unit. Unit is designed for installation in a 1/2" line; use appropriate fittings for installation in other line sizes. Apply pipe thread compound to male thread connections. Before installing unit, relieve upstream pressure completely. Install unit level and in direction of airflow as noted. Unit should be mounted to a rigid structure and should not be supported by the supply line.

WARNING: This product is intended for use in industrial compressed air systems only. Do not install where pressures or temperatures can exceed those listed above.

Unit is supplied ready for use. Air tight plugs should be removed just prior to installation to ensure filter cartridge is not exposed to air. Installation of a supply valve (not provided) can be used to isolate unit during servicing and to activate overnight drain.

A 1/4" ID flexible drain hose may be connected to overnight drain valve (3) and routed to an approved drain to prevent water accumulation in work area.

Before pressurizing, be sure bowls are turned fully clockwise. Pressurize slowly to avoid high-pressure surge.

OPERATION

Open service valve fully (1) so that handle is parallel to inlet pipe.

Inspect daily for leaks.

Check drain (2) by shutting off supply pressure and relieving downstream pressure. Accumulated liquid should drip slowly from drain.

Filter should be disassembled, cleaned and serviced periodically.

580 CARNEGIE STREET
MANTECA, CA 95337

1-800-227-2822
FAX 209-239-5114

www.motorguard.com

MAINTENANCE

WARNING: Shut off air supply and drain residual pressure before attempting to service any part of the system!

Element should be replaced when it becomes saturated with water. Remove filter bottom housing by turning t-handle CCW. Grasp element (1) by hand and remove. Install new element cartridge. Wash sludge and sediment from housing with warm, soapy water. Inspect sea (2) and replace if damaged or distorted. Reassemble housing, taking care not to damage threads. T-handle should only be hand tightened, do not use external leverage.

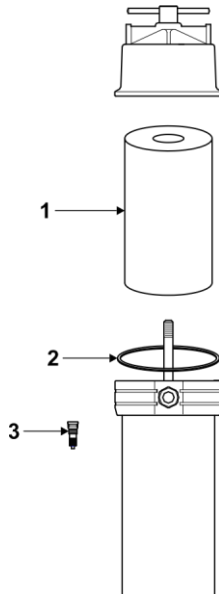

Replacement Parts

Key	Part No	Description	Qty.
1	M-710	Replacement Cartridge M-7100	1
2	106-10	Seal	2
3	RK4140	Overnight Drain Valve	1

LIMITED WARRANTY

Motor Guard Corporation assumes the responsibility of providing equipment that is free from defects in workmanship and material. Should this product fail due to a defect in workmanship or material, Motor Guard Corporation will repair or, at its option, replace the product without charge, other than the transportation charges, provided that the product is returned to the factory, transportation prepaid, within one year of the date of purchase. Please contact Motor Guard Corporation for return authorization and shipping instructions.

This limited warranty does not cover damage to the product due to neglect, misuse or accident, nor does it cover any loss, damage or expense, either direct, indirect or consequential, arising from the non-function of this product. This limited warranty notice replaces any other warranty information, implied or otherwise, enclosed with this product or appearing in literature referring to this product.