

MOTOR GUARD CORPORATION

MODEL D-12-2MS DISPOSABLE SPRAY GUN FILTER MERCHANDISING STRIP

FEATURES



The Motor Guard D-12-2MS is a high-impact point-of-sale merchandising strip that presents the product in an accessible, easily refillable strip while saving valuable shelf space. Ideal for mobile tool distributors and jobber stores, the item is guaranteed to drive impulse sales.

FEATURES

- Full Color Header Card
- Heavy-Duty Vinyl Mounting Strip
- Heavy-Duty S-Hook
- (4) D-12-2 Disposable Spray Gun Filter PK/2

SPECIFICATIONS

Dimensions: 4" Wide x 36" Long

INSTALLATION

Mount strip securely to shelving using S-hook provided [1]. Hook may be closed for a more secure installation in mobile applications.

Beginning with second clip from bottom [2], add carded product, skipping every two clip spaces until strip is full.

Secure product by tucking under tab [3] as shown.

Check and refill often.

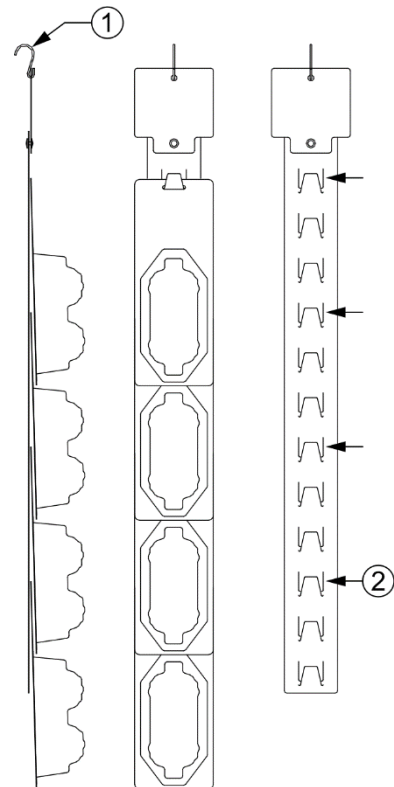
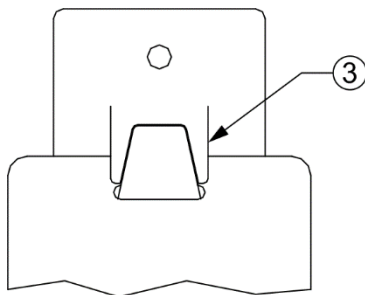

REFILL ORDER NUMBERS

Model	Order No.	Description
D-12-2	00112	DISPOSABLE SPRAY GUN FILTER, PK/2

580 CARNEGIE STREET
MANTECA, CA 95337

1-800-227-2822
FAX 209-239-5114

www.motorguard.com