

MOTOR GUARD CORPORATION

MODEL MHT-7200 HIGH TECH COMPRESSED AIR DRYER

INSTALLATION

The MHT-7200 High Tech Air Compressed Air Dryer is an advanced desiccant dryer / oil removing filter with an integrated, disposable cartridge. The unit removes water and oil vapor from compressed air for spray booths and critical refinishing operations and provides for the quickest, cleanest cartridge change in the industry.

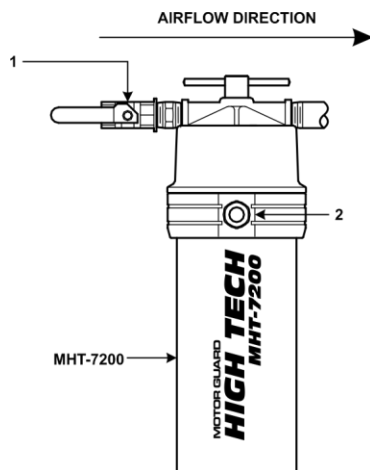

FEATURES.

Combines an activated carbon inner element to remove oil vapor to >.003 ppm with a high-capacity silica gel desiccant dryer that delivers -40°F dew point air. Color change indicator changes from blue to pink, signaling the need to replace cartridge. Uses (1) **M-720** drop-in replacement cartridge.

SPECIFICATIONS

Inlet/Outlet Size:	1/2 NPT
Nominal Airflow Rating:	30 SCFM
Oil Removal Rating:	.003 ppm
Maximum Inlet Pressure:	125 PSIG
Outlet Pressure Range:	2-125 PSI
Operating Temperature Range:	32-120 °F

Install unit in spray booth or near critical operation with at least 20 feet of supply line between unit and compressor. Failure to maintain this distance will cause excessive water vapor to pass through unit. Unit is designed for installation in a 1/2" line; use appropriate fittings for installation in other line sizes. Apply pipe thread compound to male thread connections. Before installing unit, relieve upstream pressure completely. Install unit level and in direction of airflow as noted. Unit should be mounted to a rigid structure and should not be supported by the supply line.



WARNING: This product is intended for use in industrial compressed air systems only. Do not install where pressures or temperatures can exceed those listed above. Not for use on breathable air applications.

Unit is supplied ready for use. Air tight plugs should be removed just prior to installation to ensure desiccant and activated carbon are not exposed to air. Installation of a supply valve (not provided) can be used to isolate unit during servicing and should be closed when unit is not in use.

Before pressurizing, be sure T-handle is turned fully clockwise. Pressurize slowly to avoid high-pressure surge.

OPERATION

Open service valve (1) fully so that handle is parallel to inlet pipe

Inspect daily for leaks.

Check color change indicator (2) often and replace cartridge when indicator has turned completely pink.

Dryer should be disassembled, cleaned and serviced periodically.

580 CARNEGIE STREET
MANTECA, CA 95337

1-800-227-2822
FAX 209-239-5114

www.motorguard.com

Rev 06/23 33172

MAINTENANCE



WARNING: Shut off air supply and drain residual pressure before attempting to service any part of the system!

When indicator paper (3) visible through sight glass is pale pink in color, replace cartridge by turning T-handle CCW and lowering bowl. Grasp cartridge (1) by hand and remove. Install new cartridge. Wash sludge and sediment from bowl with warm, soapy water. Inspect seal (2) and replace if damaged or distorted. Replace indicator (3) in sight glass from the inside of the bowl using a pick or similar instrument (see illustration below). Take care not to touch the new indicator paper with wet fingers. Reassemble bowl, taking care not to damage threads. T-handle should only be hand tightened, do not use external leverage.

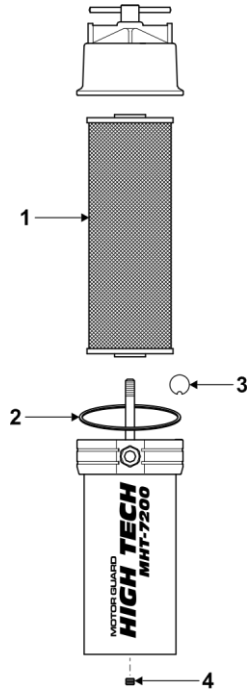

Replacement Parts

Key	Part No	Description	Qty.
1	M-720	Replacement Cartridge M-7200	1
2	106-10	Seal	1
3	RK7200	Indicator Paper	1
4	RK4138	Hex Plug	1

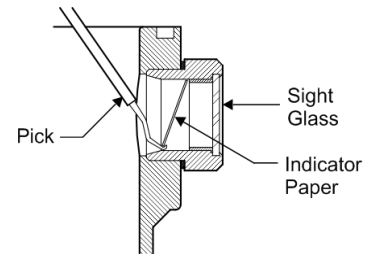

Indicator Paper Replacement

LIMITED WARRANTY

Motor Guard Corporation assumes the responsibility of providing equipment that is free from defects in workmanship and material. Should this product fail due to a defect in workmanship or material, Motor Guard Corporation will repair or, at its option, replace the product without charge, other than the transportation charges, provided that the product is returned to the factory, transportation prepaid, within one year of the date of purchase. Please contact Motor Guard Corporation for return authorization and shipping instructions.

This limited warranty does not cover damage to the product due to neglect, misuse or accident, nor does it cover any loss, damage or expense, either direct, indirect or consequential, arising from the non-function of this product. This limited warranty notice replaces any other warranty information, implied or otherwise, enclosed with this product or appearing in literature referring to this product.