

# MOTOR GUARD CORPORATION

## MODEL RF-2011 AUTOMATIC DRAIN

### FEATURES

The Model RF-2011 Automatic Drain is designed to automatically drain your compressor tank at specified intervals. It provides a hands-off, low maintenance solution to the task of tank draining which will extend the tank life, lower operating costs and improve shop air quality.

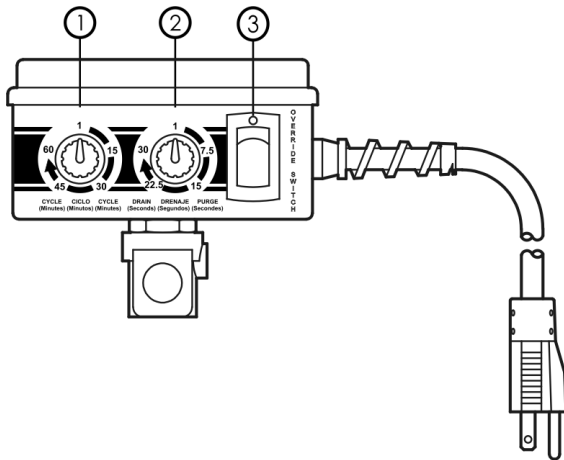

### FEATURES

- Continuously Adjustable Drain and Cycle Times
- Installs Easily
- Manual Override Switch
- Reliable, Clog-Resistant Valve
- Wye Strainer Included

### SPECIFICATIONS

Adjustable Cycle Time:	1-60 Min
Adjustable Drain Time:	1-30 Sec.
Max. Working Pressure:	200 PSI
Max. Fluid Temperature:	165 F
Ambient Oper. Temperature:	35-165 F
Enclosure:	NEMA 1
Electrical Supply:	115V/1Ph/60Hz
Nominal Current:	.25 Amps
Pipe Size:	1/4 NPT

### INSTALLATION



**WARNING:** This product is intended for use in industrial compressed air systems only. Do not install where pressures or temperatures can exceed those listed above.

**WARNING:** Completely relieve all pressure from the system before attempting to install the drain. Disconnect compressor from all external sources of pressure and electrical power. Employ approved lockout/tagout devices while working on the system. Failure to follow these directions can result in serious personal injury and death.

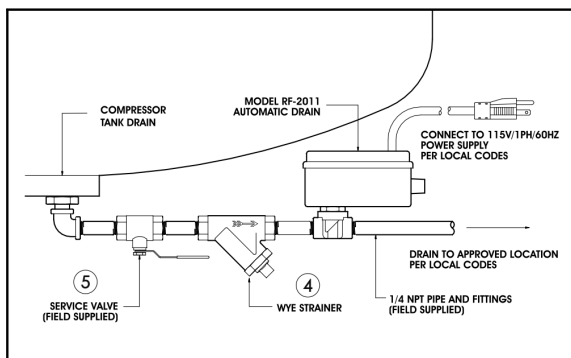

To prevent scale and debris from entering the solenoid valve, the Wye Strainer (4) must be installed upstream of the unit in the location indicated. Install drain in proper flow direction as indicated. A field supplied manual shutoff valve (5) may be installed upstream of the Wye Strainer and Drain Unit to facilitate service.

For best results, the drain should be mounted at a point lower than the tank drain outlet and all piping should be pitched downhill to drain. In cases where normal installation is not possible, the drain may be mounted at a point higher than the (b) the drain cycle is adjusted to account for increased volume.

Connect unit to an approved, properly grounded electrical supply.

### OPERATION

**Warning:** Drain should only be activated when compressor is in operation. When the compressor is shut down, power supply to drain should be disconnected. Failure to follow these directions will cause the solenoid coil to overheat and fail prematurely.

Rotate the Cycle knob (1) on the front of the unit to a setting from 1 to 60 minutes. This controls the period of time between drain activations. Rotate the Drain knob (2) to a setting from 1 to 30 seconds. This controls the period of time the drain is open for each cycle. Observe drain operation over time

580 CARNEGIE STREET  
MANTECA, CA 95337

1-800-227-2822  
FAX 209-239-5114

[www.motorguard.com](http://www.motorguard.com)

and adjust cycle accordingly. The drain should remain open long enough the discharge accumulated water but not much longer. Too long a drain time will waste energy and too short a time will allow excessive water to accumulate.

**Manual Override:** A manual override switch (3) is located on the front of the unit. Activating this switch will place the solenoid valve in a continuously open position. The switch will glow red when in the on (valve open) position.

## MAINTENANCE

**WARNING:** Completely relieve all pressure from the system before attempting to service the drain. Disconnect drain unit from all external sources of pressure and electrical power. Employ approved lockout/tagout devices while working on the system. Failure to follow these directions can result in serious personal injury and death.

The Automatic Drain will provide years of service if it is regularly and properly maintained. The following procedure should be performed on a **monthly** basis:

1. Disconnect electrical supply and depressurize Drain as instructed above.
2. Remove Drain and flush the solenoid inlet and outlet ports with a safe oil-cutting detergent such as *Lestoil* or *Fantastic*. Take care that water and detergent is kept away from all electrical components. **Do not remove cover or submerge unit in liquid. Failure to follow this warning may result in serious injury, death and property damage.**
3. Remove plug on Wye strainer assembly, remove and clean screen with detergent. Reassemble strainer.
4. Replace the drain and reconnect power.

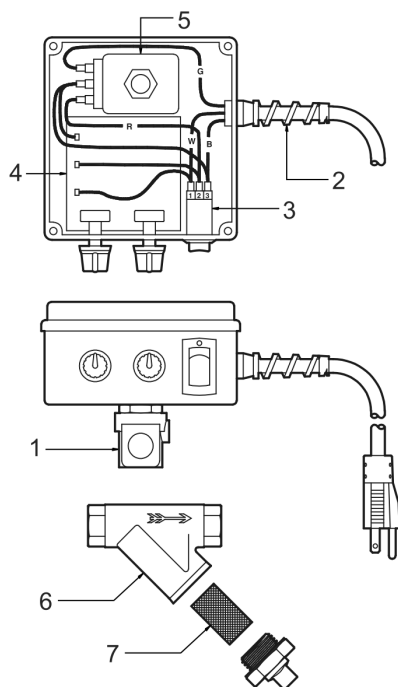

### Replacement Parts

Key	Part No	Description
1	VK5702	Solenoid Valve Kit with Coil and Wire Terminals
2	PK5700	Power Cord Kit with Strain Relief and Wire Terminals
3	SK5700	Switch Kit with Wire Terminals
4	TK5700	Timer Board Kit with Knobs, Mounting Screws and Terminals
5	CK5700	Solenoid Coil Kit with Wire Terminals
6	RF2035	Wye Strainer with Screen
7	SSK202	Replacement Screen for Wye Strainer

**Solenoid Disassembly:** If the drain is bleeding air continuously and the override switch is in the closed position it may be necessary to disassemble the solenoid valve to clear the seat of foreign materials.

### Tools Required:

1. Small Slotted Screwdriver
2. #2 Phillips Screwdriver
3. Small Adjustable Crescent Wrench

1. Disconnect Drain from external pressure and power sources as directed above.
2. Remove cover by removing (4) screws.
3. Whole holding body of valve, remove hex nut which retains solenoid valve to coil. Note orientation of valve so that it may be reinstalled in the same manner.
4. Remove stem assembly by carefully turning stem CCW. Do not strike or twist the stem with any object, as doing so will damage it.
5. Inspect the valve seat and carefully remove and foreign material.
6. Inspect the plunger assembly and remove any foreign material. Safe detergent may be used here.
7. Reassemble solenoid and valve by reversing the above procedures. Take care that the actuator cover is carefully aligned over the pin and that the outer cast portion is positioned on the outer side of the solenoid.
8. Reassemble solenoid and coil, taking care to orient valve correctly in flow direction.

## LIMITED WARRANTY

Motor Guard Corporation assumes the responsibility of providing equipment that is free from defects in workmanship and material. Should this product fail due to a defect in workmanship or material, Motor Guard Corporation will repair or, at its option, replace the product without charge, other than the transportation charges, provided that the product is returned to the factory, transportation prepaid, within one year of the date of purchase. Please contact Motor Guard Corporation for return authorization and shipping instructions.

This limited warranty does not cover damage to the product due to neglect, misuse or accident, nor does it cover any loss, damage or expense, either direct, indirect or consequential, arising from the non-function of this product. This limited warranty notice replaces any other warranty information, implied or otherwise, enclosed with this product or appearing in literature referring to this product.